



Change your **mind**. Change your **mood**. Change your **skin**.

ADAPT
acoustical treatments

Artistically unique and acoustically practical, ADAPT Acoustical Treatments answer the call for projects that demand form and function. ADAPT systems give you the ability to easily interchange artwork within a single frame. Any image can be recreated on a fabric 'skin' for endless design potential in every residential and commercial setting.

ADAPT allows for a quick and cost-effective focal-point change on one framing system. The ADAPT Acoustical Treatment System is patent pending.

COLOR

From sharp, black and white to vivid, color-rich saturation— ADAPT images pop. Shadows, fades and gradients are ever-present, creating realistic, natural images.

DYEFUSION TECHNOLOGY

Unique image intensity is achieved through our advanced dye-sublimation printing process that heat-fuses dye within the fibers of the fabric skin. An ultra-fine saturation allows sound waves to travel fluidly through the fabric's weave, maintaining lab-tested acoustic values. Dyes are 25-year fade resistant and 100% UV resistant.

SKIN

Each ADAPT skin is made of light-weight, washable, wrinkle-free fabric. The edges are trimmed with a silicone gasket for skinning and re-skinning ease. Additional skins can be folded and easily stored.

FRAME

Ultra-lightweight, brushed aluminum frames are engineered for warp-resistance. Mounting hardware is fully adjustable, minimizing uneven wall surface defects. Framing systems can accommodate multi-wall surfaces. Frame color choices are unlimited with color-matching capabilities (CMYK).

SIZE

Framing systems are constructed in custom and standard sizes. Seamless, large format projects are easily created within available dimensions of 10 ft x 150 ft.

MODEL OPTIONS

ADAPT model options include wall-mount, freestanding partition, hanging baffle and hanging cloud. For creative custom and standard application ideas, see the *ADAPT Acoustical Treatments: Design Concepts* brochure.

ENVIRONMENTAL IMPACT

Acoustic core materials are bound with water-based, latex adhesives for an odor-free, no off-gassing result. The following ADAPT components have a high post-consumer recycled material content: cotton acoustical core (80%), fiberglass acoustical core (50%), and aluminum frame (60%). Both the frame and core are re-usable. Add a fresh image skin and the entire system is renewed—re-skinning is re-using. ADAPT is eligible for LEED credits in multiple categories across numerous rating systems. [Be sure to ask us about LEED Pilot Credit 24: Acoustics.](#)

FLAMMABILITY

ADAPT fabrics carry a Class A flammability rating in accordance with ASTM E84.

ORIGIN

ADAPT components are proudly made in the USA.

EASE OF INSTALLATION

ADAPT Acoustical Treatments are easily installed—one person can change an 8 ft x 8 ft skin in minutes. No special tools or training are required to achieve a professional installation. Complete instructions are included in each shipment as well as online at www.soundproofcow.com

FIT AND FINISH

Prior to shipment, frames are cut to specification and test fitted with skins in our facility, ensuring a hassle-free on-site installation.

LEAD TIME

Quality assured, custom ADAPT products are delivered in 2 to 3 weeks. For fastest delivery, choose expedited shipping and expect your custom order in 1 week.

SERVICES

Acoustictrade creates custom, cost-effective acoustic solutions. With 12+ years experience in the acoustic industry, our pros are available to assist in all phases of your project. Appropriate acoustical coverage can be computed using our advanced engineering software, ensuring your unique space is properly enhanced—aesthetically and acoustically.

FULL PRODUCT LINE

Fiber, wood, glass and more comprise our complete product line of innovative acoustic treatments. Visit www.soundproofcow.com to see it all.

SAMPLES

Sample custom skins are available upon request. We also offer 30 in x 30 in ADAPT loaner samples for a hands-on, no-obligation trial period.

ADAPT SKIN REMOVAL

To remove fabric for replacement or cleaning. Gently pull the tab (in the lower left corner of the frame) to loosen the gasket seal. Continue gently pulling in a slow diagonal motion until the gasket releases from the frame, exposing the core at the bottom corner. The entire fabric skin will remove with ease by holding the exposed corner of the skin and gently pulling all around the frame edge.

CARE AND MAINTENANCE

Dry clean or machine wash separately in a cold, gentle cycle. Tumble dry, low or air-dry. Do not wring. When dry, re-install the skin. Wrinkles will disperse over a 24 hour period. If wrinkles persist, iron (low heat) or steam only on reverse side.

ADAPT Images 3 Ways

- 1 Provide an image*—photo, vector, pattern, solid—to be transferred onto an ADAPT skin.
- 2 Supply us an idea—our design team is poised and ready to custom create an image specifically for you.
- 3 Choose from our gallery of exclusive, original images provided by contributing artists and designers.



Model: ADT-1.75W
9.5 ft wide x 7 ft high

Of the sound that comes in contact with this panel, 80% is absorbed, reducing echo and improving speech intelligibility.

IMAGE REQUIREMENTS

- Images file types: .pdf, .eps, .jpeg, .tif, .psd, .ai
- Logo file types: .ai, .eps
- Resolution: 300 DPI
- Digital images should be print ready.
- Minor alterations (i.e. cropping, size adjustments) are included and performed in-house with no additional fees.
- Major alterations (i.e. color adjustments, graphic enhancements) performed at an additional cost and determined on a per job basis. Free, no-obligation quotes provided.

- Files may be sent via hard copy (CD/DVD)
- Files may be up-loaded instantly at www.soundproofcow.com/uploadfiles.php
Follow the instructions for an easy up-load.

Email questions or concerns regarding images to: images@soundproofcow.com

*The lawful right to reproduce all images submitted must be represented and warranted by the customer. In the event that issues arise from the reproduction of submitted artwork, the sole responsibility lies with the customer.



MODEL

ADT-1.75W

DIMENSIONS

Thickness - 1 3/4 in

Frame Size

Custom - Up to 10 ft x 150 ft

Standard - 3 ft x 5 ft, 3 ft x 9 ft, 8 ft x 8 ft

3 ft x 5 ft

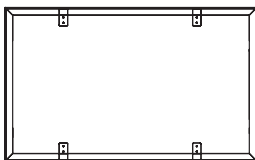

3 ft x 9 ft

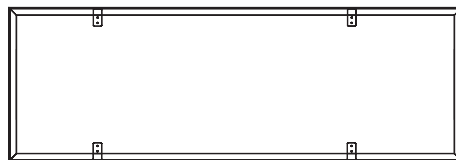

8 ft x 8 ft

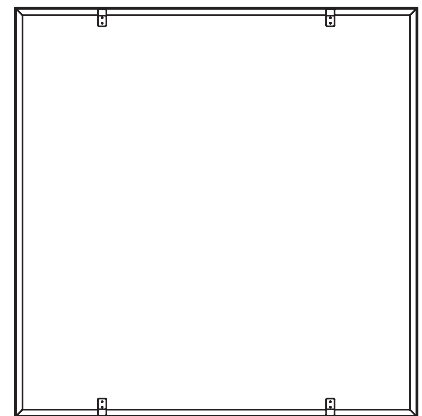



MODEL

ADT-3.0W

DIMENSIONS

Thickness - 3 in

Frame Size

Custom - Up to 10 ft x 150 ft

Standard - 3 ft x 5 ft, 3 ft x 9 ft, 8 ft x 8 ft

3 ft x 5 ft

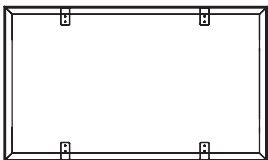

3 ft x 9 ft

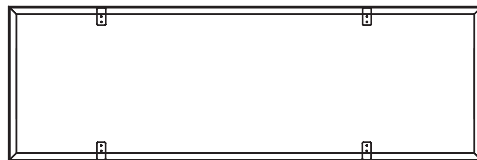

8 ft x 8 ft

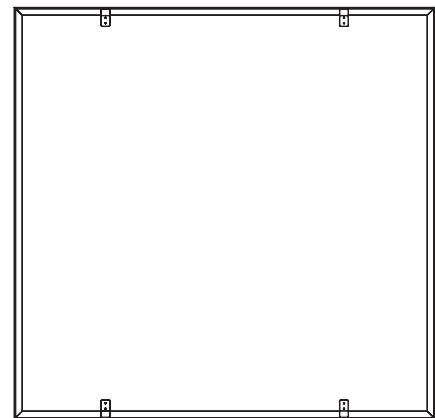

ACOUSTIC CORE OPTIONS

ACOUSTIC FIBERGLASS

- Thickness – 1 in and 2 in
- Density – 6 PCF
- Flammability – ASTM E84 Class A
- 50% Post-Consumer Recycled Content
- Binders, rapidly renewable bio-based materials
- GREENGUARD Indoor Air Quality Certified®
- GREENGUARD Children and Schools Certified
- No Formaldehyde, Phenol, Acrylics or Artificial Colors
- No VOCs
- No Off-Gassing
- No Mold
- No Odor
- Made in the USA

ACOUSTIC COTTON

- Thickness – 1 in and 2 in
- Density – 3 PCF
- Flammability – ASTM E84 Class A
- 80% Post-Consumer/Commercial/Industrial Recycled Content
- Thermally Bonded
- No VOCs
- No Off-Gassing
- Mold and Pest Resistant
- No Odor
- Made in the USA

ACOUSTIC FOAM

- Thickness – 1 in and 2 in
- Density – 0.70 PCF
- Flammability – ASTM E84 Class A
- Fiber Free
- Ultra-light Weight
- No VOCs
- No Off-Gassing
- Mold and Pest Resistant
- No Odor
- Made in the USA

COMPONENTS

FRAME

- Material – Aluminum
- Gauge – 14 (0.075 mil)
- 60% Post-consumer Recycled Content
- 100% Recyclable
- Standard Finish – Brushed Aluminum
- Optional Finish – Powder Coated
- Standard Powder Coated Colors
 - Glossy Black, Flat Black, White and Silver
- Custom Powder Coated Colors Available
- Made in the USA

FABRIC

- Material – 100% Polyester
- Weight – 5 ounces
- Flammability – ASTM E84 Class A
- 100% Acoustically Transparent
- Machine-sewn Silicone Seal, pliable for the life of the fabric
- Made in the USA

ACCOLADES

ADAPT was bestowed with the coveted Gold Award at NeoCon 2011.



ACOUSTIC DATA

Core	Thickness	125Hz	250Hz	500Hz	1000Hz	2000Hz	4000Hz	NRC
Fiberglass	1"	.05	.26	.77	1.04	1.04	1.03	.80
	2"	.32	.81	1.08	1.06	1.03	1.04	1.00
Cotton	1"	.13	.22	.62	.85	.90	.96	.65
	2"	.25	.69	1.11	1.12	1.03	1.07	1.00
Foam	1"	.18	.23	.50	.82	.96	.99	.65
	2"	.31	.60	.75	.90	1.00	1.00	.80

SOUND ABSORPTION COEFFICIENT

1/3 Octave Center Center Frequency (Hz)	Absorption Coefficient 1 in	Absorption Coefficient 2 in
100	0.04	0.20
125	0.05	0.32
160	0.10	0.45
200	0.14	0.66
250	0.26	0.81
315	0.41	0.97
400	0.54	1.04
500	0.77	1.08
630	0.86	1.10
800	0.97	1.09
1000	1.04	1.06
1250	1.03	1.05
1600	1.05	1.03
2000	1.04	1.03
2500	1.04	1.02
3150	1.00	1.03
4000	1.03	1.04
5000	1.04	1.05

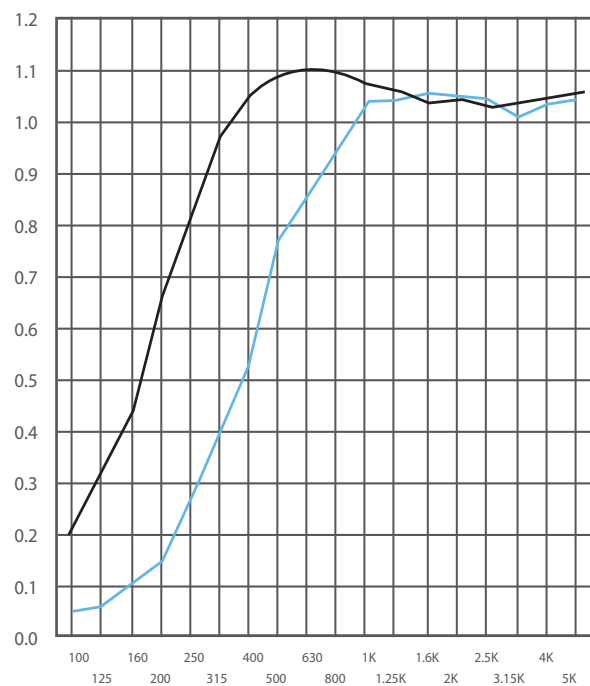

FREQUENCY (Hz)

1 in 2 in

1

On a smooth, clean, non-abrasive surface, place the ADAPT frame pieces in the desired installation configuration. Using a 3 mil hex wrench and supplied hardware, connect the frame pieces together with the 90° Corner Connectors.

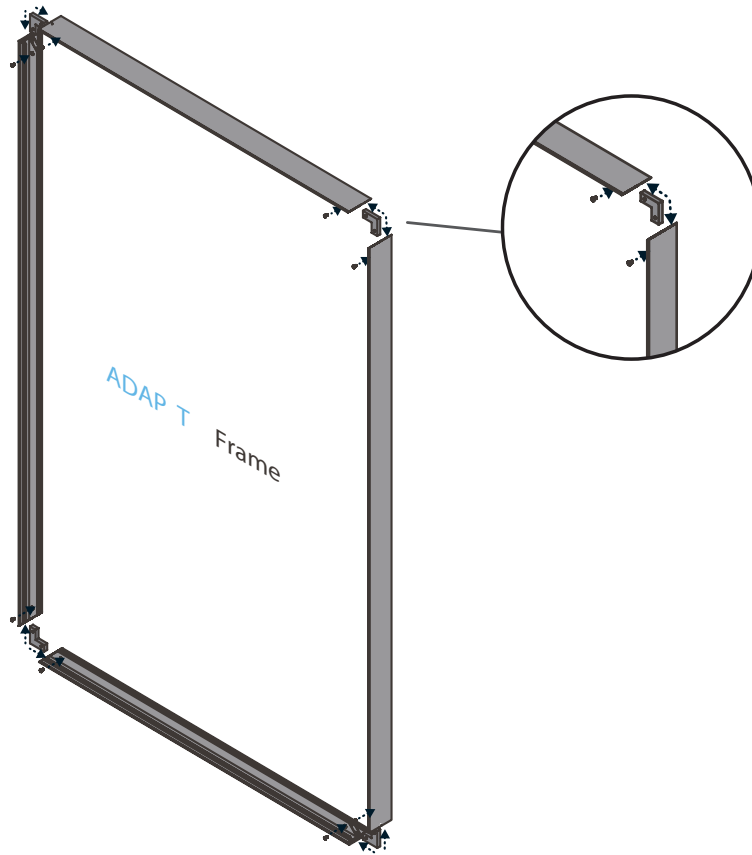

2

Starting with the top Z-Brackets and taking frame dimensions into consideration, mount the Z-Brackets in the proper location onto the wall surface. Install the Z-Brackets 1¾ inch below the finished height of the ADAPT frame. The Z-Brackets should be loosely installed so that the frame fits easily into the Z-Brackets.

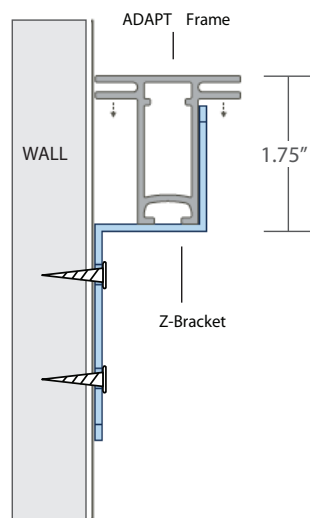

3

To accommodate irregular wall surfaces, adjust the frame by tightening or loosening the Z-brackets. Be sure the frame is level, then tighten the Z-brackets. Adjust (tighten or loosen) the Z-Brackets to accommodate irregular wall surfaces. The frame should hang perfectly square with no bending or contortion. Install the bottom Z-brackets to complete frame installation.

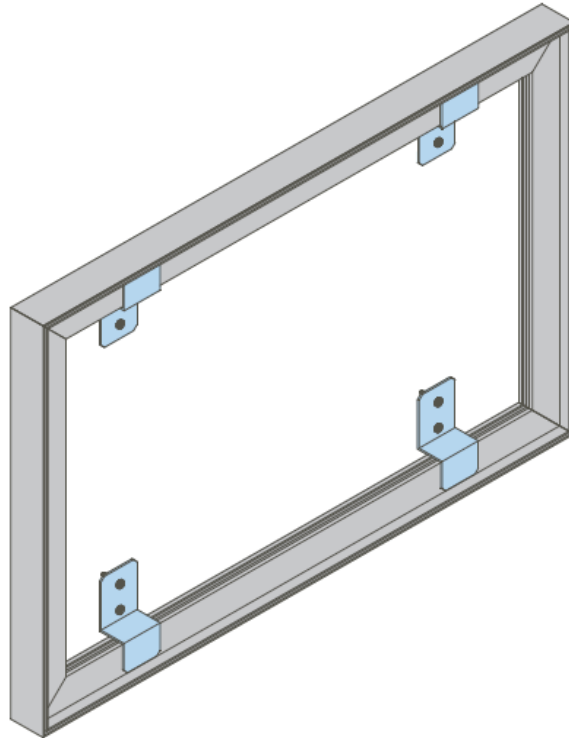

4

Install the acoustic core within the ADAPT frame. Field modifications are required to fit the acoustic core inside the innermost area of the frame. The acoustic core may be friction fit between the rails, glued, or mechanically fastened to the wall surface.

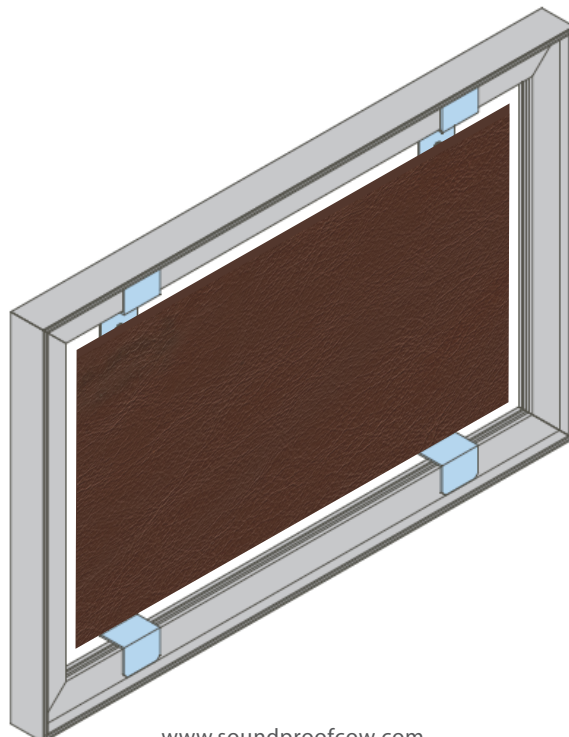

5

To install the fabric skin, start in the corners. Fold the fabric edge and insert the silicone gasket into the frame channel. Continue inserting the gasket into the channel, working your way toward the center from each corner.

6

If fabric bunching occurs causing wrinkles, gently adjust the fabric in the channel until the appearance is smooth and wrinkle-free.

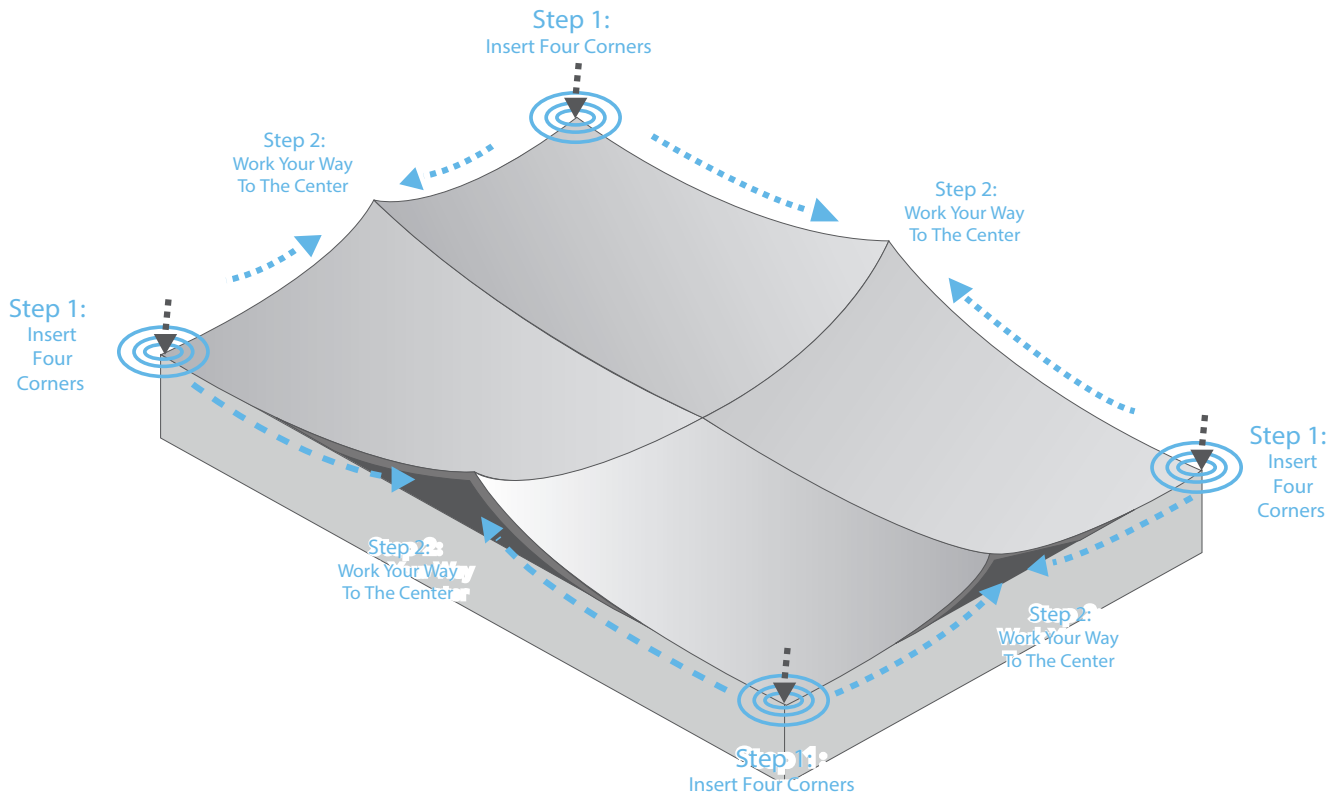

For a how-to video demonstration, visit www.soundproofcow.com/install

FRAME PROFILES

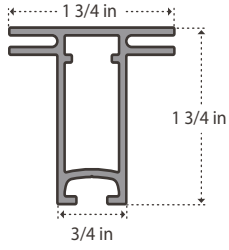

MODEL ADT-1.75W

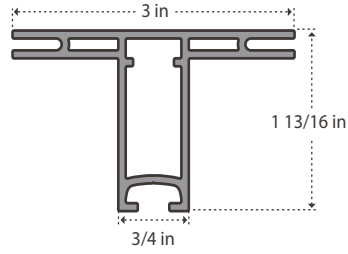

MODEL ADT-3.0W

MOUNTING HARDWARE

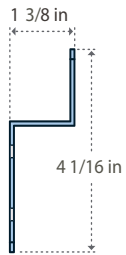

1.75 Z-Bracket (side)

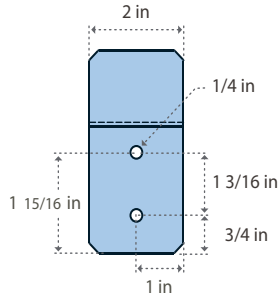

1.75 Z-Bracket (front)

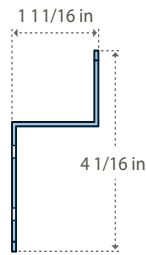

3.0 Z-Bracket (side)

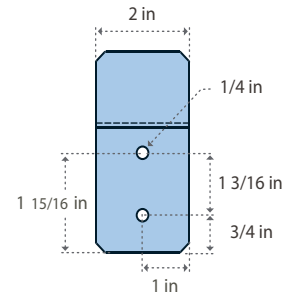

3.0 Z-Bracket (front)

COUPLINGS

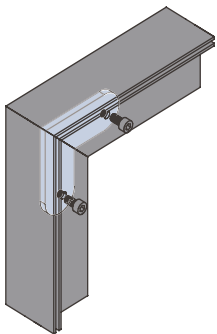

90° Coupling

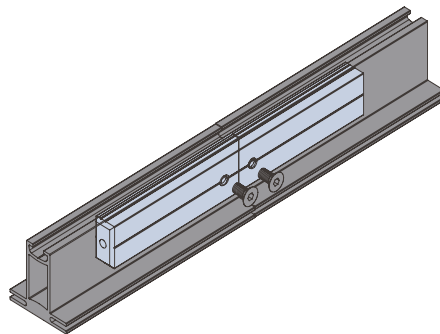

180° Coupling



soundproofCOW.com
there's something about the cow. 

866.949.9269 | www.soundproofcow.com